

Product Information
Welding

Contents

1	Foreword	3
2	Hot gas welding	4
2.1	Work station	4
2.2	Seam preparation	4
2.3	Method	4
2.4	Welding faults	6
2.5	Finishing the weld seam	7
2.6	Weldability of different types of material	7
3	Heated element welding	8
3.1	Fold welding	9
3.2	Heated element butt welding for pipes and fittings	11
3.3	Heated element socket welding	15
4	Heated coil welding	16
4.1	Basic conditions	16
4.2	Welding seam preparation	16
4.3	Welding process	16
5	Friction welding	17
5.1	Method	17
5.2	Preparation for welding	17
5.3	Welding process	17
6	Extrusion welding	19
6.1	Preparation	19
6.2	Temperature	19
6.3	Effect of humidity	20
6.4	Equipment	21
6.5	Finishing the weld seam	22
6.6	Avoidance of cavity formation in welded items	22
6.7	Seam shapes	23
6.8	Variables which affect joint seam quality	24

7	Testing the weld seam strength	25
7.1	Manual testing	25
7.2	Welding factor (tensile test) (DVS 2203, -2)	25
7.3	Technological bending test	25
8	Weld connections	28
8.1	Structural strength of weld connections	28
8.2	Weld seam position	29
8.3	Stresses	31
9	Advice	33
10	Standards and sources	34
11	Appendix	37

1 Foreword

The term welding of plastics refers to the indissoluble bonding of thermoplastics using heat and pressure with or without the use of an additional material. This term does not cover the processes ambiguously described as cold or swelling welding because in such cases the surface is partially dissolved and glued.

All welding methods take place when the material at the gap and surface zone is in the plastic state. The thread-like molecules of the pressed together parts combine and intertwine to form a homogeneous union.

Basically only plastics of the same type, e. g. PP with PP can be welded together and within this provision only those with the same or similar (neighbouring) molecular weight and same density, different colours however do not have an effect. PE-HD and PE-LD cannot be welded together.

The only exception to this is the possibility of a satisfactory welded union between u-PVC and acrylic glass (PMMA).

2 Hot gas welding

(see DVS 2207-3)

2.1 Work station

The equipment at a welding work station should include, besides the hot gas welding machine with nozzles (3, 4 and 5 mm quick welding nozzles, fan welding nozzles and tacking nozzles, profiled wire nozzles), a thermometer, an air volume meter, an oil and water separator. Thermometers with needle shaped probes have proved to be especially useful as they can be inserted into the nozzle for measuring the temperature. Accurate temperature measurement 5 mm in the nozzle (see table page 38) is a pre-condition for accurate welded seams with a high welding factor (see page 25).

2.2 Seam preparation

The most important types of seam are DV (X) and V seams plus the fillet seam for sheets to be welded at right angles. The sheets must be perfectly aligned and chamfered at 30°. This can be done using a plane, truing tool, miller, knife or spoke shave.

The most used seam is the DV seam in which welding is carried out from both sides alternately to avoid distortion. For thin sheets and in constructions where welding can only be carried out from one side the V seam is recommended. The welding surfaces of the sheet and wire must be cleaned mechanically.

Dirt, grease, perspiration and oxide coatings must be removed mechanically to achieve a high weld factor. Cleaning with a solvent is not sufficient.

2.3 Method

Optimum results are only obtained when the base material and wire are equally plastic. The equipment must be checked regularly for temperature and air volume and adjusted as necessary.

Before the welding wire is put in position the start point is heated briefly until the surface is dulled. Before each new welding pass the welding bead and the oxide layers, whose occurrence is accelerated at high temperatures, are scraped off mechanically using special tools.

To reduce the distortion it is important that each welding seam is allowed to cool in air before a new welding pass is worked out. If thick sheets are to be welded by the DV seam process then the sheet must be turned over after each welding pass so that the seams are arranged in sequence opposite each other. When welding, a heated zone of equal width (approximately 5–8 mm) on both sides of the seam must be maintained. The achievement of double beading, in which both items reach the plastic melt zone, is important for a good connection between sheets. The molecule chains flow into one another and double beading results.

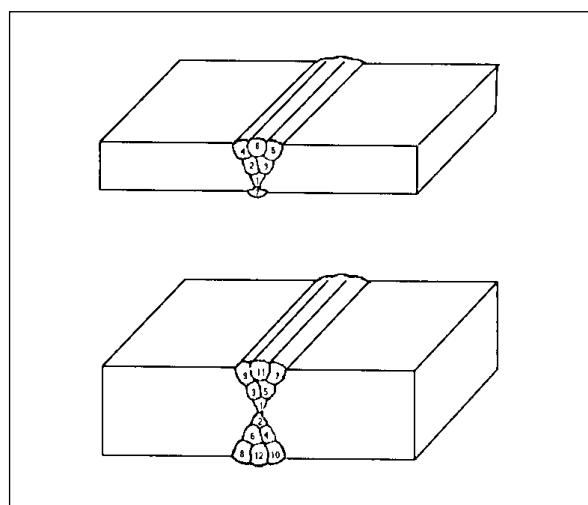

The most important types of weld seams for hot gas welding

Examples for the build up of weld seams

material thickness [mm]		welding wire quantity x diameter [mm]
V-seam	2	1 x 4
	3	3 x 3
	4	1 x 3 and 2 x 4
	5	6 x 3
DV-seam (X-seam)	4	2 (1 x 4)
	5	2 (3 x 3)
	6	2 (3 x 3)
	8	2 (1 x 3 and 2 x 4)
	10	2 (6 x 3)

Using the round nozzle

This method requires more manipulative skill and ability than working with the quick welding nozzle (see below). The wire should be held at a right angle to prevent lateral cracks (when the angle is too acute) and upsets (when the angle is too obtuse).

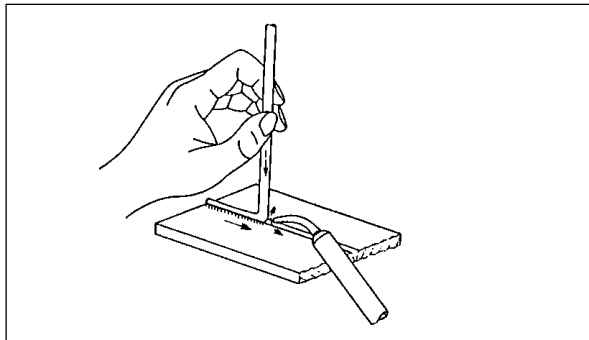

Hot gas welding with torch separate from filler rod

Using the quick welding nozzle

In comparison with round nozzle welding, welding with the quick welding nozzle allows welding speeds to be doubled and gives greater safety. Special nozzles are used through which the wire is led and pre-heated. The air outlet at the sheet end of the nozzle is narrow and only heats a specific required area of the sheet. Various nozzles are available which correspond to the various wire diameters and profiles.

Using the tacking nozzle

Welding with the tacking nozzle serves to fix together the parts to be welded. In this case fusion is brought about but without any additional wire. The tacking nozzle must be used with V seams in order to guarantee perfect bonding of the root face zones and to avoid a notch effect at the bend. Use of the tacking nozzle is also recommended when, for example, connections are to be fixed to the external surface of a piece under manufacture.

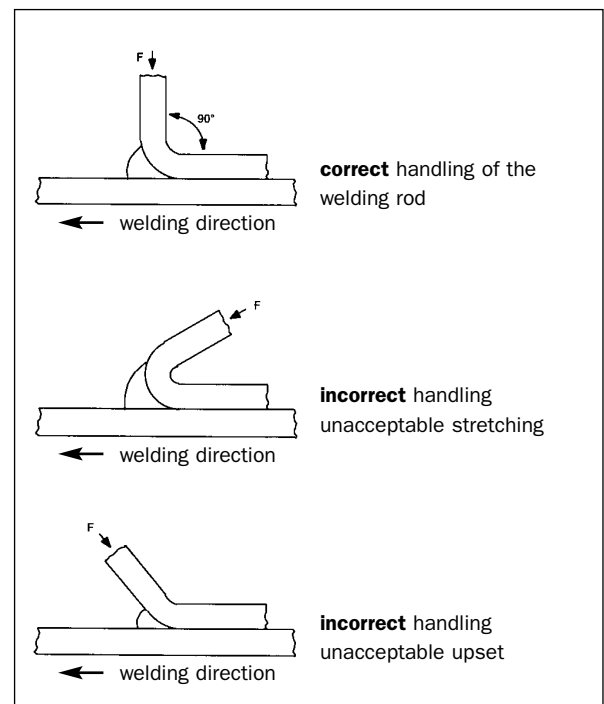

Welding rod handling

2.4 Welding faults

- Sheets and wire have not been heated equally (the heated zones left and right of the welding wire have not been heated equally).
- Temperature and air volume are not correct.
- Sheet and wire are not clean enough.
- The air is not water, oil and dust free.
- Lack of root fusion of the V seams.
- Air has been trapped within the welding seam area.
- The volume of the welding wire is insufficient to prevent notches in the welding seam area.
- Incorrect arrangement of the sheets.
- Welded too quickly: the welding wire remained round and was not sufficiently shaped resulting in no or incomplete bonding.
- Thermal damage has been caused as a result of using too high a welding temperature. The supposed advantage of quicker welding is paid for by thermal damage to the molecule chains which in extreme cases converts the long-chain formations almost back to their original monomer. This is particularly true for polyethylene and polypropylene.

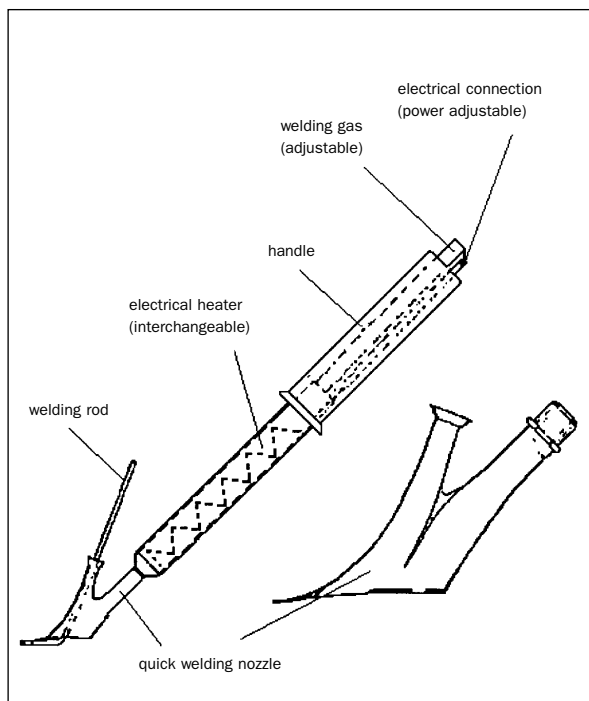

Quick welding nozzle

2.5 Finishing the weld seams

As a rule the seams are left unfinished. They can however be finished using planes, sanders or rasps but attention must be paid that no notches are formed. After several sandings using increasingly fine sanding paper weld seams can also be polished (e. g. PVC, PETG).

The table of hot gas welding guide values is on page 38.

2.6 Weldability of different types of material

Basically only plastics of the same type, e. g. PP with PP can be welded together and within this provision only those with the same or similar neighbouring molecular weight and same density, different colours however do not have an effect. Practically it means that particular materials always can only be welded together with sufficient steadiness within one or two neighbouring melt-flow index groups. The corresponding melt-flow index groups can be taken out of the moulding material descriptions according to DIN EN ISO 1872 part 1 (PE) and DIN EN ISO 1873 part 1 (PP). The MFR-values, relevant for the welding, can also be taken out of the corresponding moulding material description. **PE-HD and PE-LD cannot be welded together.**

The only exception to this is the possibility of a satisfactory welded union between u-PVC and acrylic glass (PMMA) or SIMOLUX.

PE-HD (PE 63 / PE 80 / PE 100)

Pipeline parts and sheets with MFR 0.3–1.7 and 0.2–0.7 are capable for being welded together. This means that the melting viscosity, i. e. the melting behaviour, is very similar at heating-up. This statement is included in the DVS 2207, part 1 and furthermore was confirmed in an announcement from the DVGW (Deutscher Verband für Gas und Wasser).

PP-H 100 (type 1), PP-B 80 (type 2), PP-R 80 (type 3)

Weldability is given within the melt-flow index group 006/012 (MFR 190/5: 0.4–1.0 g/10 min). You can read this statement in the DVS 2207, part 11.

PVDF

There are two PVDF types on the market, manufactured by different polymerisation processes: the emulsion-PVDF and the suspension-PVDF. Without revealing details it needs to be emphasized that semi-finished products of both processes can be welded between each other with a high connection value.

The DVS-regulation 2207, part 15 not only deals with heated element butt welding but also with socket welding of extruded pipes, injected fittings as well as sheets.

3 Heated element welding

Pre-heating is by means of a PTFE coated heating element. Because of the direct contact the heat transfer is much more intensive than for hot gas welding; the heat distribution over the cross section of the material is more favourable, no zone of the material is more thermally stressed than is required for welding. The resulting connections have very low stresses. Heated element welding takes place by bringing the heated contact surfaces together under a specific pressure and cooling under pressure. Modern equipment is fitted with data collectors which allow welding records to be prepared and printed.

The following points are decisive for weld seam quality: (see also figure on page 9):

a. Welding seam preparation

The first and most important requirement for heated element welding is cleanliness of the materials to be welded and of the heating element. Teflon films and coatings make cleaning the heating element easier and prevent the plastic sticking to the heating element when hot. This is particularly necessary when welding PVC.

b. Heating element temperature

As a rule for thicker-walled semi-finished products lower temperatures – within the tolerances (see tables on pages 39 to 48) – are used, for a correspondingly longer time.

c. Adaption time

The perfectly smooth surfaces for welding are held evenly in the hot tool and under the pressures given in the tables (see tables on pages 39 to 48) until a bead of melted material appears.

d. Pre-heating time

In order to obtain an as even as possible heat flow in the material the pre-heating pressure is reduced linearly to zero in the next part of the cycle. A sharp temperature boundary zone between plasticised and unplasticised material is avoided. Stresses are reduced.

e. Change-over time

To achieve a weld with a high weld factor (see page 25) the quick bonding of the parts for welding is decisive. This is particularly true for PVC.

f. Time for build-up of bonding pressure

During the time for build-up of bonding pressure, the pressure is comparatively slowly increased. Sudden use of full pressure would press the hot plastic material out of the welding zone which would result in an inadequate weld factor.

g. Bonding pressure and cooling time

Bonding pressure and cooling time depend on the type of material and the wall thickness. The full strength of the welded seam is reached after cooling under bonding pressure to room temperature. The part can be removed from the machine. **Do not** cool down with water or air (stresses).

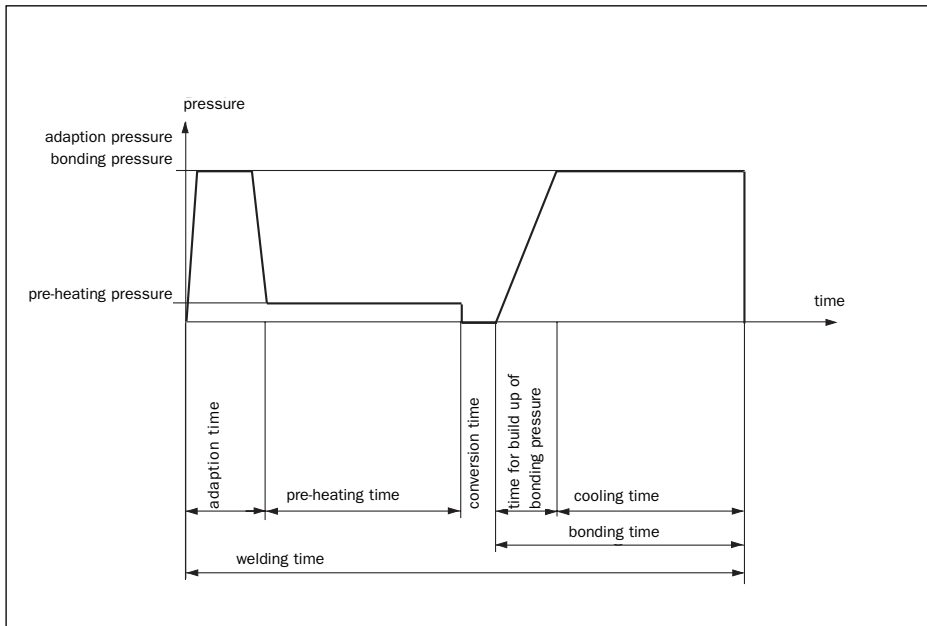

Pressure/time-diagram;
sequence for heated
element butt welding

3.1 Fold welding

This combined method (see figure, page 10) is a modification of heated element butt welding. The cutting edge of the heated blade is melted into the plastic under pressure. For larger sheet thicknesses a small groove (approx. 0.5 x sheet thickness) can be milled or sawn before melting to save pre-heating time and the plastic from long exposure to the heat. When the required depth has melted – 2/3 to 3/4 of the sheet thickness – so much heat from the bottom heater of the heated blade has penetrated to the back of the seam that true heat deformation is obtained as a result of the subsequent folding. Normally the heated blades are chamfered at 80 – 86° to guarantee a perfect 90° fold. Blades with a sharper angled cutting edge must be used for folding obtuse angles.

On long folded profiles a clear curvature can often be seen after cooling. Apart from the longitudinal distortion attention must be particularly given to the cooling shrinkage stresses in the welded zone, which are strengthened by the internal stresses within the semi-finished material arising from the manufacturing process. Narrow side uprights lead to large distortions, wide and therefore more rigid uprights to lower distortion. Furthermore, with larger sheet thicknesses (from approx. 6 mm) it is advisable to heat the back of the sheet with a second heated blade (width of the heated blade min. 2 x the sheet thickness) or with hot air to prevent undesirable stresses. Folds at right angles to the direction of extrusion show much less bowing.

We furthermore recommend from a sheet thickness of 10 mm onwards to work out of the sheet a V-groove of approximately 50% of the thickness by machining or sawing prior to the welding process. This groove should be provided in order to avoid a too high emerging out of the welding zone. On top of this the welding period is reduced by the lower heating-up time.

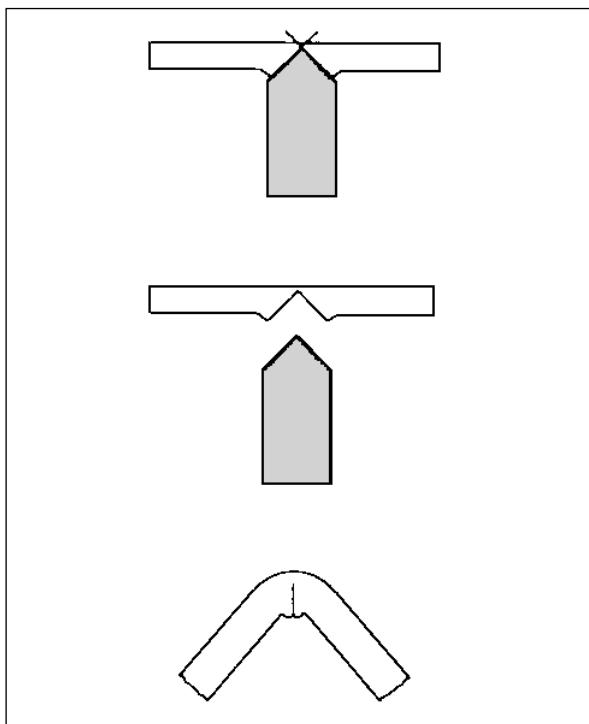

Fold welding

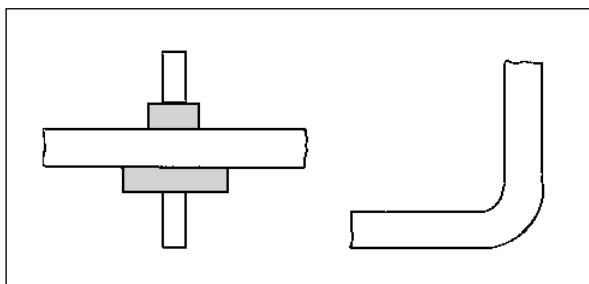

Bending

Guide values for folding and bending on the Wegener Bending and Folding Machine BM 201

	adjusted temperature		time [s] for 1mm thickness
	[°C] upper	lower	
Folding			
PE	220	140	~ 30
PP	230	150	~ 45
PVDF	240	160	~ 45
Bending			
PVC	220	170	~ 30

Welding methods:

For the indissoluble connection of SIMONA® pipes and fittings we recommend the following practically proven methods:

- Heated element butt welding (see page 11)
- Heated element socket welding (see page 15)
- Heated coil welding (see page 16)

see also DVS guidelines

- 2207-1 for PE
- 2207-11 for PP and
- 2207-15 for PVDF

3.2 Heated element butt welding for pipes and fittings

(see DVS 2207-1, -11 and -15 and figure, page 12)

Basic conditions for heated element butt welding, heated element socket welding and heated coil welding

The welding area must be protected from adverse weather conditions (e. g. effects of humidity, wind, strong sunshine and temperatures below +5 °C). In sunshine pipe wall temperatures should be equalised by timely covering of the welding areas of the unevenly warmed pipes.

If it can be guaranteed that, by taking suitable measures such as

- pre-heating
- canopies
- heating

a sufficient and regular pipe wall temperature for welding can be maintained then welding can be carried out at any outside temperature.

The dew point graph has to be taken into consideration. The parts to be welded must have the same temperature level. Experimental welds have to be made and inspected.

The bonding surfaces of the parts to be welded must be free from contamination. Cleaning must be carried out immediately before welding. The same applies to the heating element which must be cleaned with PE-Cleaner and non-fibrous paper. To prevent the pipe sticking to the heating element and to make the removal of the pipe easier the metal surfaces should be teflonised. The pipe ends opposite the welding positions should be closed to prevent cooling by strong draughts during the welding process.

Before heated element butt welding the faces of the pipe are machined and brought to the welding temperature by means of the heating element and the resultant plastified welding surfaces – after removal of the heating element – joined together under pressure.

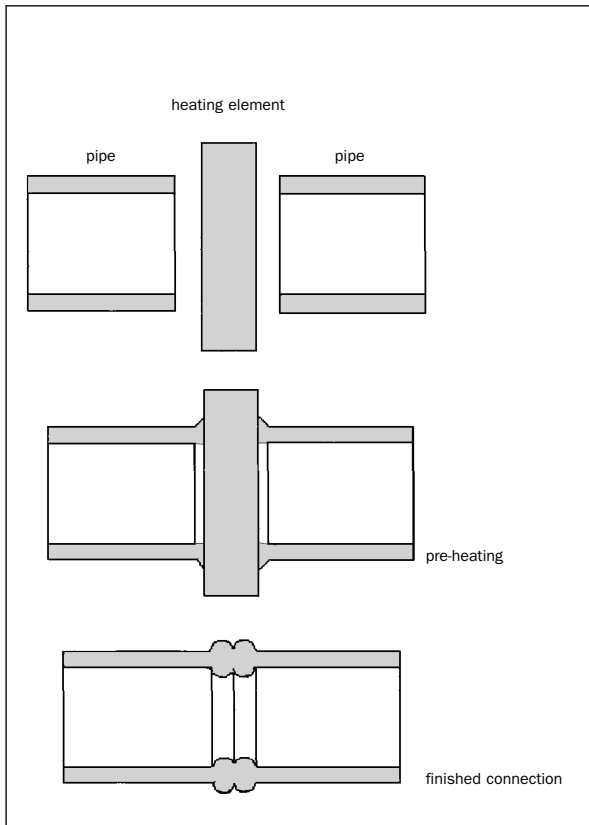

Principle of heated element butt welding

Welding seam preparation

The pipeline parts should be axially aligned before clamping in the welding machine. The longitudinal freedom of the parts to be welded should be guaranteed by carrying out appropriate measures e. g. adjustable pulley brackets.

The surfaces to be bonded should be prepared with a plane whilst clamped. A cutting depth of ≤ 0.2 mm should be chosen. Any shavings which may have fallen into the pipe should be removed using a clean tool. On no account should the prepared welding surfaces be touched by the hands.

After preparation the plane-parallelism must be checked. The remaining gap must not exceed the value given in the table on page 13. At the same time it should be checked that the mismatch of the pipe ends is less than 10 % of the wall thickness. If need be the wall thicknesses in the weld seam area should be equalised by machining.

Maximum width of gap between prepared welding ends

external diameter of pipe d [mm]	width of gap a [mm]
≤ 355	0.5
400 – < 630	1.0
630 – < 800	1.3
800 – ≤ 1000	1.5
> 1000	2.0

Welding process

The heating element which has been heated to welding temperature (for PE-63/PE 80 see figure in the right column; in practice welding machine manufacturers recommend for PE 100 220 °C independent on the wall thickness) is placed between the parts to be welded and the bonding surfaces are pressed onto both sides of the heating element with the correct adaptation pressure. A temperature of 240 ± 8 °C applies for PVDF resp. 210 ± 10 °C for PP.

Temperature control is carried out using a rapid response surface temperature measuring instrument with a contact fluid if need be or with a temperature probe, melting salts resp. IR temperature measuring instrument.

The force required to align or bond can be calculated from the welding surfaces and the specific pressure. Normally the welding machine manufacturers give the values in table form as most equipment is hydraulic not dynamometric. The work piece movement pressure is to be added to this given pressure. This is affected by the friction of the machine components and the weight of the pieces to be welded.

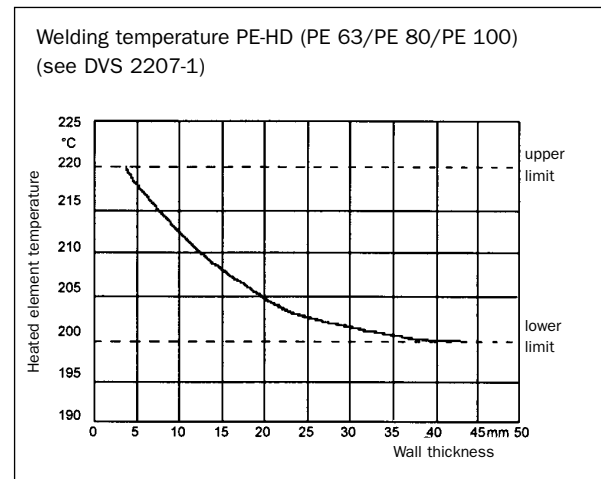

Alignment is completed when a bead has formed on the complete perimeter of the parts to be welded which accords with the values given in tables on pages 39–48. During the pre-heating time, which starts now, the contact pressure is reduced almost to zero.

After heating-up the bonding surfaces are removed from the heating element without being damaged or contaminated. The time for removal of the bonding surfaces, withdrawal of the heating element and contact of the bonding surfaces is known as conversion time and should be kept as short as possible.

The surfaces to be welded should be brought together with a speed as close to zero as possible. The pressure should then be slowly increased (for times see tables on page 39–48) and kept steady until complete cooling has occurred. The joining pressure values given in the tables may vary due to a differing consideration of the moving pressure of the machine for sheets and pipes.

Rapid cooling of the weld seam area or the use of coolants is not permitted.

For large wall thicknesses – from about 20 mm – a more regular cooling during the cooling time can be obtained by covering the welding zone which has a favourable influence on the welding seam quality. After bonding there must be over the whole circumference a regular continuous double bead (see figure).

If the weld bead requires finishing this is best done before cooling – approx. $\frac{2}{3}$ of the cooling time – is complete. There is a danger that cutting work on the cold bead will cause notches. With hard materials such as PVDF tears in the material may occur.

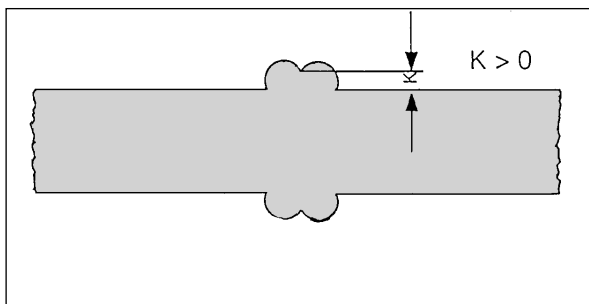

Bead formation for heated element butt welding

3.3 Heated element socket welding

(see DVS 2207-1, -11 and -15)

Basic conditions

Pipe and pipe-line parts are lap welded. Using a socket or nozzle shaped heating element both surfaces are heated to welding temperature and then joined. The measurements of the pipe ends, heating element and socket are harmonised so that a bonding pressure builds up during bonding.

For pipe diameters

- ≥ 63 mm for PE-HD and PP
- ≥ 50 mm for PVDF

suitable welding equipment must be used.

Welding seam preparation

The bonding surfaces of the pipes should be prepared using a skiving tool or scraper. The heated element has to be taken into consideration acc. to DVS guideline 2208-1; for method A – without mechanical finishing of the welding surface – see table 8, for method B – with mechanical finishing of the welding surface – see table 7. The fitting should be thoroughly cleaned inside with a cleaning agent (e. g. Tangit Cleaner, Henkel) and absorbent non-fibrous paper.

The pipe end should be angled on the outside at approximately 15° to

- a width of 2 mm for diameters up to 50 mm
- a width of 3 mm for larger diameters.

With manual welding a mark should be made to show the insertion depth at the pipe ends.

Welding process

The welding tools are heated to 260 ± 10 °C. Temperature control is carried out using a rapid response surface temperature measuring instrument with, if necessary, melting salts. To pre-heat first the fitting is inserted as far as the stop and then the pipe up to the mark. The parts to be welded are heated for the time given in tables on pages 49 and 50.

After the pre-heating time the fitting and pipe are pulled from the heating element and put together up to the mark or stop without distortion. The bonded pieces must be held corresponding to the tables of page 49 and 50.

Principle of heated element socket welding

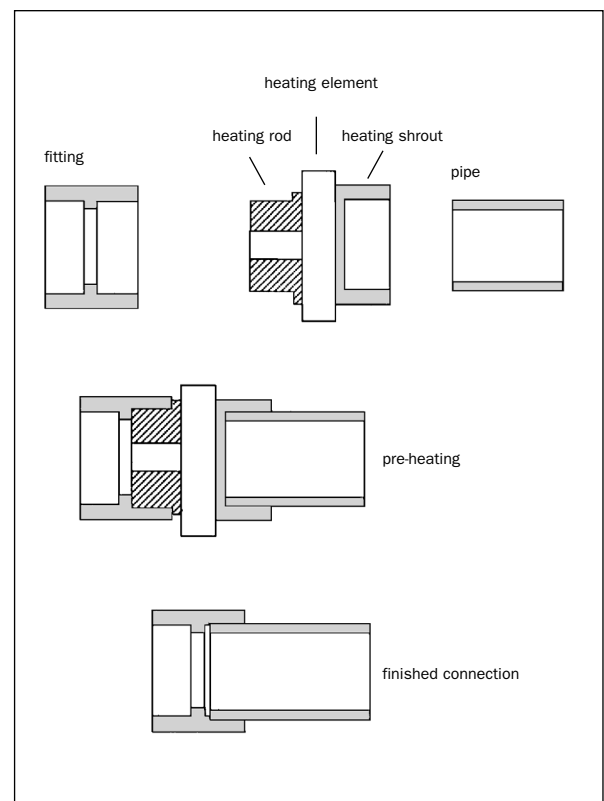

4 Heated coil welding

(see DVS 2207-1 and -11)

4.1 Basic conditions

The bonding surfaces i. e. the pipe surface and the inner surface of the socket are heated to welding temperature and welded by means of electricity passing through resistance wires (heated coil) embedded in the socket. This method is used at present for PE-HD and PP.

4.2 Welding seam preparation

Clean surfaces are decisively important for perfect welds using the heated coil welding method. The surfaces of the pipes must be prepared in the welding zone with a scraper or a rotary scraper. The inner edge must be deburred and the outer edge rounded off in accordance with figure on this page.

The fitting should be thoroughly cleaned inside with a cleaning agent (e. g. Tangit Cleaner, Henkel) and absorbent non-fibrous paper.

The degree of out-of-round in the welding zone must not exceed 1.5 % of the outside diameter. Otherwise appropriate compression clamps must be used.

When locating the fitting attention must be paid that the pieces are not tilted or forcibly inserted otherwise the heated coil could be moved or damaged.

4.3 Welding process

Only welding equipment suited to the fitting should be used. Before welding the welding equipment is adjusted to the values corresponding to the diameter and nominal pressure of the pipe. The equipment and fitting are joined by means of a welding cable. The welding process takes place automatically: with modern equipment a welding record is produced. The pipe connection can only be moved after cooling.

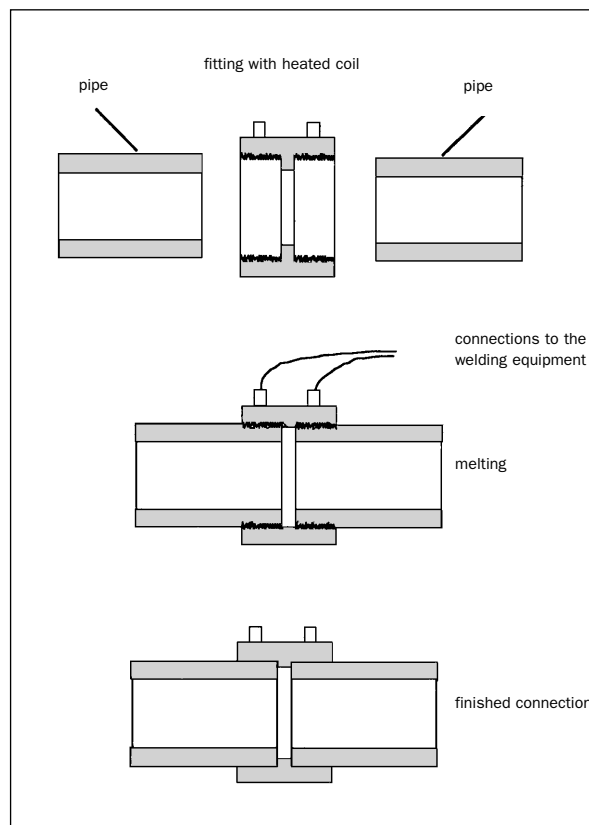

Principle of heated coil welding

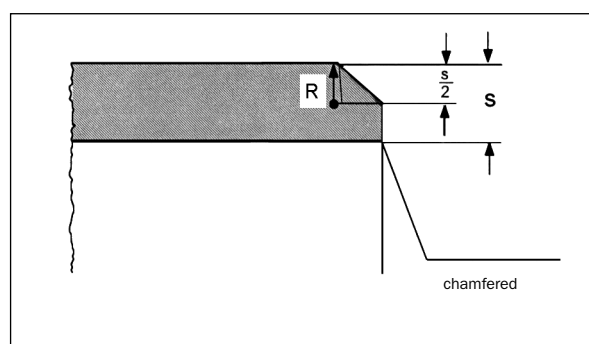

Preparation of the pipe ends

5 Friction welding

5.1 Method

In friction welding the energy required for welding is produced without supplying thermal energy and preferably without adding extra material by friction of the bonding surfaces of the parts to be welded. This causes beading and the parts are welded under pressure.

In this method one work piece is usually turned against a fixed one, so the rotation symmetric bonding surfaces can be faces or circumferential surfaces.

5.2 Preparation for welding

The bonding surfaces of the parts to be welded must be free from contamination. Cleaning agents which dissolve plastics or cause them to swell must not be used.

The geometrical formation of the bonding surfaces is important for the success of the welding. With butt joints of parts up to about 30–40 mm diameter the bonding surfaces must be faced while for pieces with a diameter of more than 40 mm one or both bonding surfaces must be given a slight crown by machine processing.

Thin walled pieces (pipes) must be supported by suitable means in the area of the bonding surfaces.

5.3 Welding process

The pieces for welding are fitted in a tool (see figure page 19); then one piece is turned against the other which is usually fixed. After reaching the welding temperature – the correct point is recognisable when paste like material is seen all round the circumference – the fixed piece is released and the turning motion of the two pieces ended as quickly as possible. The bonding pressure is maintained until sufficient cooling has occurred.

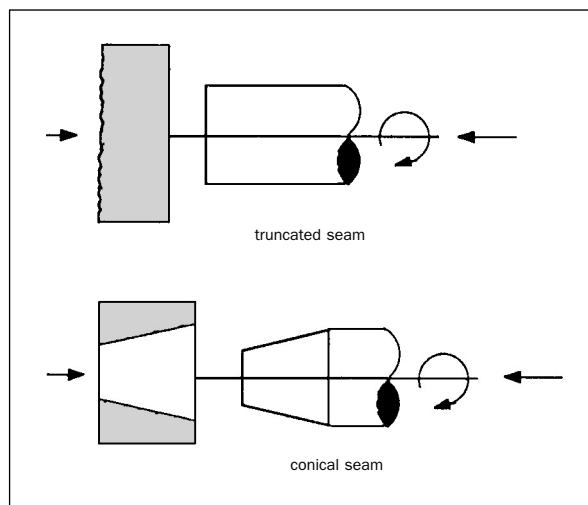

Welding the seam

The basic variables affecting friction welding are:

- Pre-heating pressure: Pressure with which the bonding surfaces are held together during turning
- Pre-heating time: Time of application of the pre-heating pressure
- Bonding pressure: Pressure for bonding the parts to be welded
- Bonding time: Time of application of the bonding pressure

In practice, depending on the diameters of the welding surfaces, circumferential speeds of about 1–4 m/sec are used. The welder must determine by preliminary tests for each application the material, work piece and inter-relating welding conditions (e. g. friction speed, pre-heating and bonding pressure).

The pre-heating pressure (friction pressure) and bonding pressure (welding pressure) are approximately 0.5–1.5 N/mm² for polyolefines and u-PVC. The aim is to keep the friction pressure so low that the plastified material cannot be forced out of the bonding area.



Principle of friction welding

left: ready to weld; right: welded

6 Extrusion welding

(see DVS 2207-4)

Extrusion welding is used, amongst other things, for connecting thick walled parts. Welding is carried out with a homogeneous welding filler. For PVC the process is limited, the extruder must not be switched off during use (danger of decomposition). For PVDF special screws have to be used. If necessary please contact the extruder producer.

6.1 Preparation

Immediately before welding the bonding surfaces, neighbouring areas and also damaged surfaces (particularly those arising from the effects of weather and chemicals) must be cleaned off mechanically back to undamaged material. Cleaning materials (e.g. acetone) which attack or modify the surface of the plastic must not be used.

Example:

Material PP, sheet thickness 10 mm, V-butt joint 60°, extruder Munsch MA 40/60, rod PP Ø 4 mm

Settings:

60° V angle, air gap 1 mm (see preparation of the welding zone), $T_M = 225-230\text{ °C}$, $T_L = 275-295\text{ °C}$, distance between the pre-heating nozzle and the substrate 10–15 mm, extruder output approx. 1.5 kg/h resulting in a welding speed of approx. 150–175 mm/min.

Welding speed: < 30 cm/min for PE/PP with a wall thickness of 10 mm

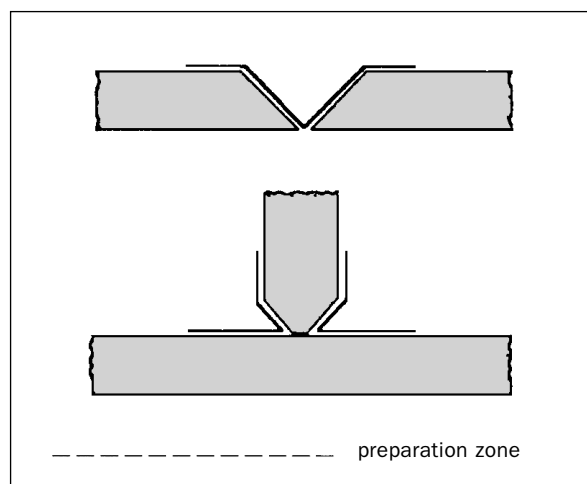

Cleaning the welding area

6.2 Temperature

	temperature of the extruded material measured at the nozzle mouth [°C]	air temperature measured in the nozzle [°C]	volume of air (volume of cold air drawn in) [l/min]
PE-HD	210–230	250–300	≥ 300
PP-H, B, R	210–240	250–300	≥ 300
PVC-U	170–180	300–360	≥ 300
PVC-C	195–205	300–360	≥ 300
PVDF	240–260	280–350	≥ 300

6.3 Effect of humidity

Plastics, also welding fillers out of polyolefines, can absorb moisture at the surface under special conditions. Tests made by an important raw material producer and by SIMONA give rise to the following conclusion:

Dependent on the material and the environmental conditions the welding filler absorbs moisture. During extrusion welding this incorporated moisture can cause bubbles in the seam resp. a rough seam surface. This phenomenon increases with increasing seam thickness (a-value).

To prevent the problem "moisture" during the welding process please pay attention to the following items:

- install a water/oil trap into the air system
- avoid temperature differences of the parts to be welded (condensation water)
- storage of the welding filler as dry as possible (e.g. heating rooms)
- pre-dry the welding filler if necessary
(air evacuation oven:
PE 80 °C/PP 100 °C, for at least 12 h)
- weld high a-values (≥ 18 mm) in several passes

Relative moisture

Formula:

$$\text{relative humidity [\%]} = \frac{\text{Quantity of existing moisture} \times 100}{\text{Max. quantity of moisture}}$$

If the level of moisture in the air remains constant, relative humidity changes as follows:

- relative humidity drops when the air is warmed and
- relative humidity rises when the air is cooled

If the air cools down to such an extent that relative humidity reaches the value of 100%, water vapour has to separate from the air in the form of mist if there is further cooling. The temperature at which this takes place is termed dew point. Therefore, condensation occurs whenever the air is cooled to below dew point.

You can determine the dew point using the table below. At a given temperature of 20 °C and a relative humidity of 60%, for example, the dew point is 12 °C.

Dew point of air in relation to the temperature and relative humidity of the air

air temperature °C	Dew point in °C in relation to the relative humidity of the air of													
	30%	35%	40%	45%	50%	55%	60%	65%	70%	75%	80%	85%	90%	95%
30	10,5	12,9	14,9	16,8	18,4	20,0	21,4	22,7	23,9	25,1	26,2	27,2	28,2	29,1
29	9,7	12,0	14,0	15,9	17,5	19,0	20,4	21,7	23,0	24,1	25,2	26,2	27,2	28,1
28	8,8	11,1	13,1	15,0	16,6	18,1	19,5	20,8	22,0	23,2	24,2	25,2	26,2	27,1
27	8,0	10,2	12,2	14,1	15,7	17,2	18,6	19,9	21,1	22,2	23,3	24,3	25,2	26,1
26	7,1	9,4	11,4	13,2	14,8	16,3	17,6	18,9	20,1	21,2	22,3	23,3	24,2	25,1
25	6,2	8,5	10,5	12,2	13,9	15,3	16,7	18,0	19,1	20,3	21,3	22,3	23,3	24,1
24	5,4	7,6	9,6	11,3	12,9	14,4	15,8	17,0	18,2	19,3	20,3	21,3	22,3	23,1
23	4,5	6,7	8,7	10,4	12,0	13,5	14,8	16,1	17,2	18,3	19,4	20,3	21,3	22,2
22	3,6	5,9	7,8	9,5	11,1	12,5	13,9	15,1	16,3	17,4	18,4	19,4	20,3	21,2
21	2,8	5,0	6,9	8,6	10,2	11,6	12,9	14,2	15,3	16,4	17,4	18,4	19,3	20,2
20	1,9	4,1	6,0	7,7	9,3	10,7	12,0	13,2	14,4	15,4	16,4	17,4	18,3	19,2
19	1,0	3,2	5,1	6,8	8,3	9,8	11,1	12,3	13,4	14,5	15,5	16,4	17,3	18,2
18	0,2	2,3	4,2	5,9	7,4	8,8	10,1	11,3	12,5	13,5	14,5	15,4	16,3	17,2
17	-0,6	1,4	3,3	5,0	6,5	7,9	9,2	10,4	11,5	12,5	13,5	14,5	15,3	16,2
16	-1,4	0,5	2,4	4,1	5,6	7,0	8,2	9,4	10,5	11,6	12,6	13,5	14,4	15,2
15	-2,2	-0,3	1,5	3,2	4,7	6,1	7,3	8,5	9,6	10,6	11,6	12,5	13,4	14,2
14	-2,9	-1,0	0,6	2,3	3,7	5,1	6,4	7,5	8,6	9,6	10,6	11,5	12,4	13,2
13	-3,7	-1,9	-0,1	1,3	2,8	4,2	5,5	6,6	7,7	8,7	9,6	10,5	11,4	12,2
12	-4,5	-2,6	-1,0	0,4	1,9	3,2	4,5	5,7	6,7	7,7	8,7	9,6	10,4	11,2
11	-5,2	-3,4	-1,8	-0,4	1,0	2,3	3,5	4,7	5,8	6,7	7,7	8,6	9,4	10,2
10	-6,0	-4,2	-2,6	-1,2	0,1	1,4	2,6	3,7	4,8	5,8	6,7	7,6	8,4	9,2

1) Linear interpolation can be performed for the purpose of approximation.

6.4 Equipment

The portable extrusion welding equipment consists of a small extruder as the plastifying unit, which is driven by e. g. a electromotor.

It is customary to pre-heat the weld joint using a fan or built-in hot air equipment connected to the air supply.

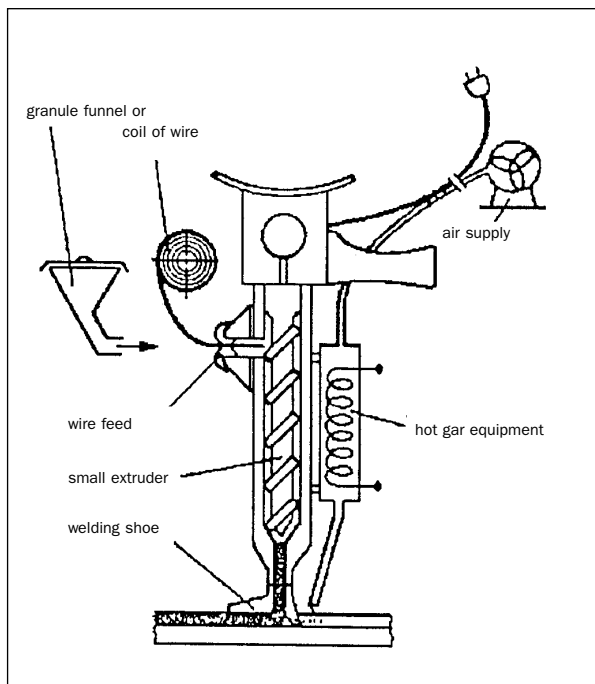

Extruder

The following features are characteristic for hot gas extrusion welding:

- the welding filler is similar to the moulding material
- the welding filler is homogeneous and completely plastified
- the bonding surfaces are heated to welding temperature by hot air
- insert depth 0.5–1.0 mm.
- the extruded material is distributed and pressed down by a welding shoe
- in comparison with hot gas welding shorter working times and higher mechanical strength properties are achieved with high seam quality and low internal stresses.

Shape of the welding shoe

The extruded welding filler is distributed and pressed down by a welding shoe (e.g. PTFE). Following factors depend on the shape of the shoe:

- filling volume
- filling speed
- material flow
- seam sealing
- even pressure

The welding shoe must be suited to the shape of the individual seam. Basically the rule is: the wider the welding seam the longer the shoe should be (see also DVS 2207-4).

Only plastics with high heat stability can be used as materials for the shoe, PTFE has been the most successful. As well as the required high heat stability this plastic has good sliding properties.

6.5 Finishing the weld seam

In principle weld seams should be so made that no additional treatment is necessary. Extrusion weld seams should have an even smooth surface and a perfectly welded zone around the circumference.

To avoid notches at the base of the seams a root face layer or seam protection may be hot gas welded.

Any extruded material that appears at the edge of the shoe – especially with highly stressed connections – should be removed using an appropriately shaped scraper.

6.6 Avoidance of cavity formation in welded items

Cavities are formed after the actual welding process. They can be reduced by changes in the speed of cooling, in the welding shoe geometry, but only by a minimum degree by changing the welding parameters.

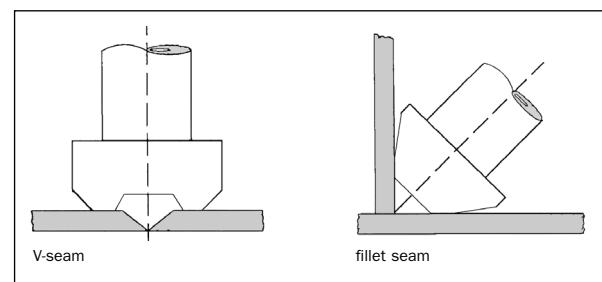

Design of a welding shoe

In particular cavities appear with increased wall thicknesses. They arise because after the solidification of the seam surface a load-bearing external skin is formed which resists the volume contraction, cavities are formed as an inevitable result.

Slow and thereby low in cavities cooling of the weld seam can be achieved by using a cloth cover, which must be sufficiently heat resistant and insulating (e.g. glass wool with aluminium foil).

At the same time stresses in the seam area are reduced.

6.7 Seam shapes

T-joint, HV-seam (half V seam) with fillet seam, DV seam

The projection g serves to support and guide the welding shoes.

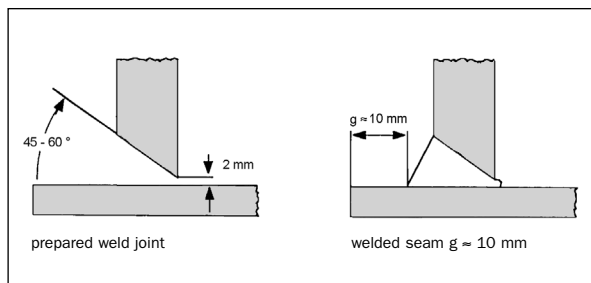

T-joint, HV-seam with fillet seam

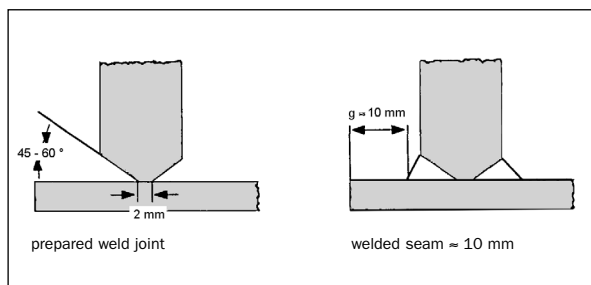

T-joint with double-HV-seam

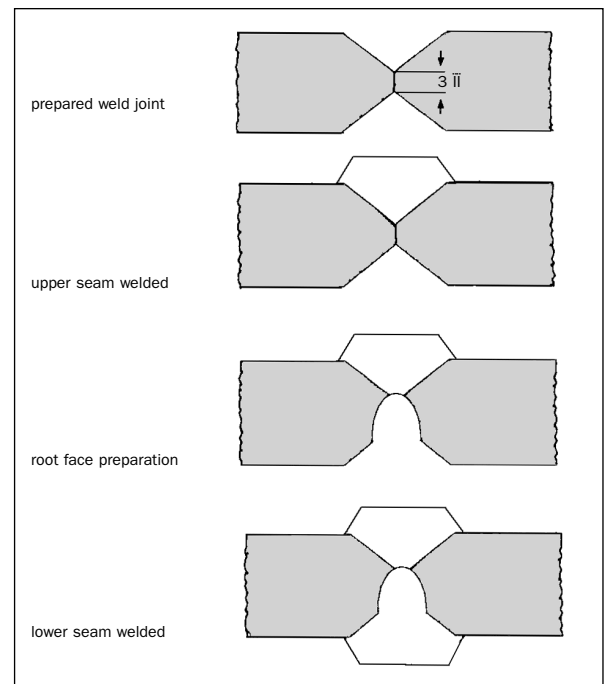

Butt joint with DV-seam - weld seam without fissures

6.8 Variables which affect joint seam quality

- Cleanliness of base material, welding filler and pre-heating air
- Welding filler temperature
- Base material temperature
- Hot gas temperature
- Welding extrudate throughput
- Hot gas volume
- Welding speed (forward feed)
- Welding pressure

Examples of the dimensional design of the welding nozzle and the crosssection of the air outlet aperture for welded seam widths of up to 40 mm

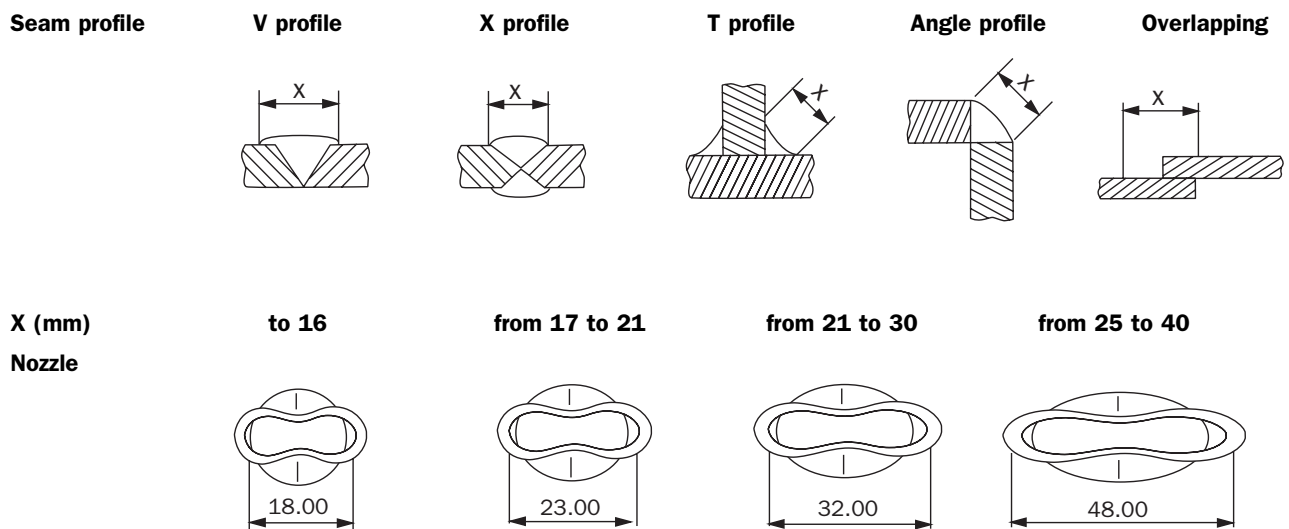

7 Testing the weld seam strength

7.1 Manual testing

DVS Guideline 2203-5: “This method for the technical bending test is a simple test adapted for carrying out in the workshop. Because of the forces involved this method is limited to test thicknesses of ≤ 10 mm.

The test piece with the finished weld seam is bent over a rounded 6 mm thick rod in one quick movement (see figure) until it breaks or the free ends of the test piece touch the rod.”

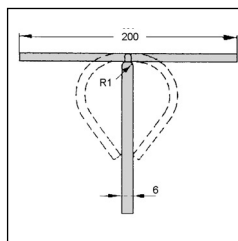

Schematic presentation of the manual test

7.2 Welding factor (tensile test)

(DVS 2203 -5)

	Hot gas welding		Heated element butt welding		Extrusion welding	
	short term factor	long term factor	short term factor	long term factor	short term factor	long term factor
PE-HWU/-HWST	0,8	0,4	0,9	0,8	0,8	0,6
PP-DWU/-DWST	0,8	0,4	0,9	0,8	0,8	0,6
PVC-CAW/-MZ/-C	0,8	0,4	0,9	0,6	–	–
PVDF	0,8	0,4	0,9	0,6	–	–

The weld factor is the relationship of the tensile strength of the weld seam to that of the base material.

The short term factors are valid for loading times of up to an hour. Consequently for pre-fabricated parts calculations only the long term factors are to be used.

$$\frac{\text{tensile strength of the weld seam}}{\text{tensile strength of the base material}}$$

7.3 Technological bending test

(DVS 2203-5)

The technological bending test serves – together with other tests – to judge how the welding has been carried out. Bending angle and break formation demonstrate the deformability of the connection and thus the quality of how the welding has been carried out. The endurance characteristics of a welded connection can only be determined to a limited extent from the bending test results.

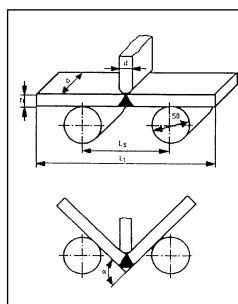

Schematic presentation of the machine test

Dependence of minimum bending angle of SIMONA semi-finished products on the sample thickness

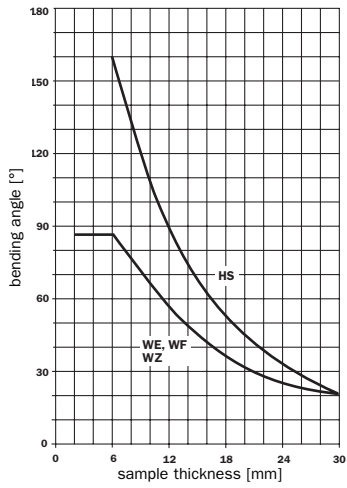

SIMONA®
PE-HWU/HWST

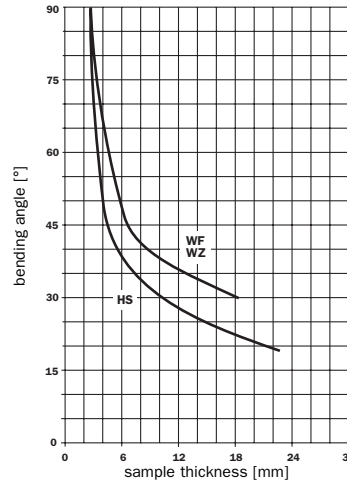

SIMONA® PVDF

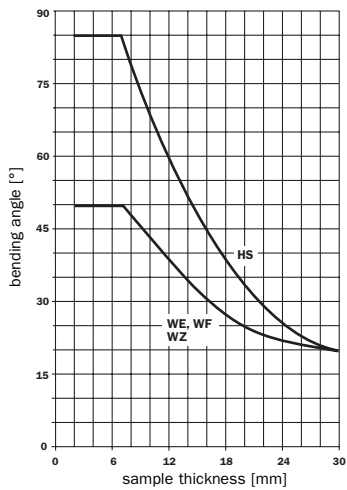

SIMONA® PP-C,
PP-DWU/DWST

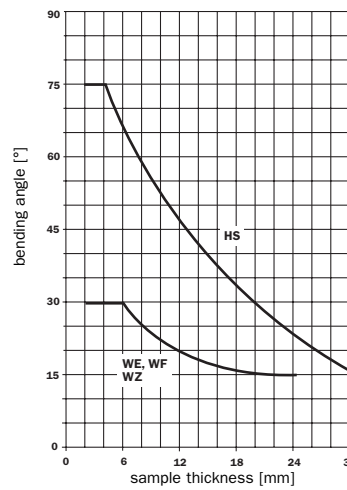

SIMONA® PVC-CAW

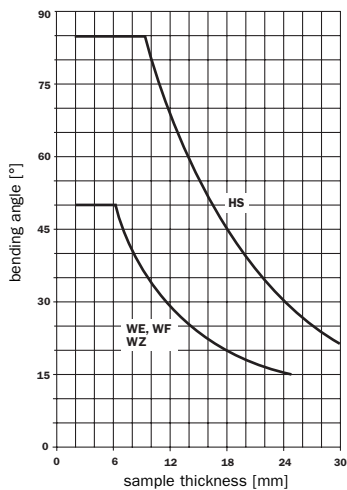

SIMONA®
PVC-MZ/HSV

- HS: heated element butt welding
- WF: hot gas welding with torch separate from filler rod
- WZ: hot gas draw welding
- WE: hot gas extrusion welding

Dependence of minimum bending distance of SIMONA semi-finished products on the sample thickness

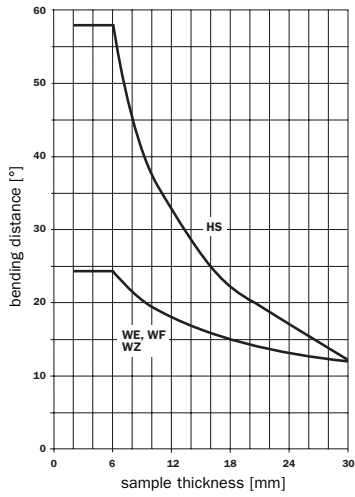

SIMONA®
PE-HWU/HWST

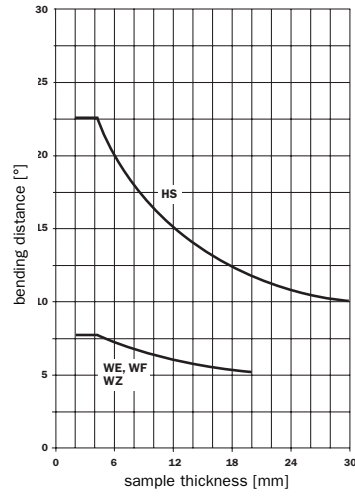

SIMONA® PVDF

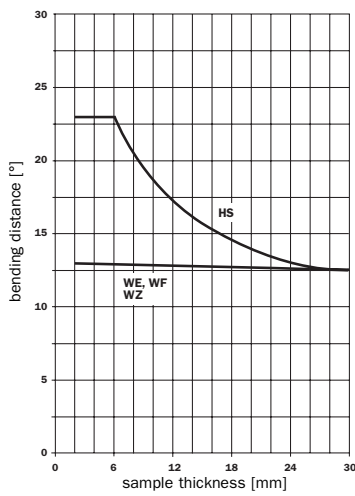

SIMONA® PP-C,
PP-DWU/DWST

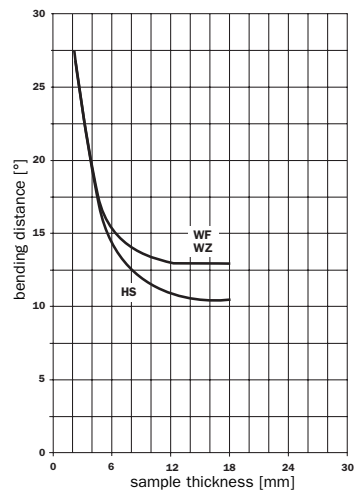

SIMONA® PVC-CAW

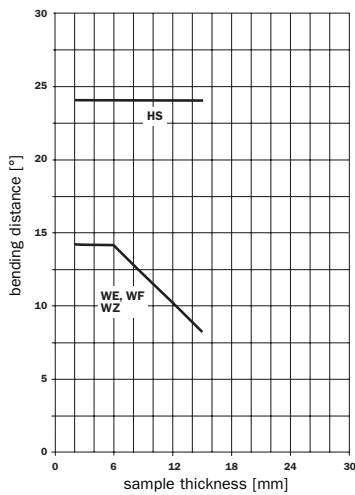

SIMONA®
PVC-MZ/HSV

- HS: heated element butt welding
- WF: hot gas welding with torch separate from filler rod
- WZ: hot gas draw welding
- WE: hot gas extrusion welding

8 Weld connections

8.1 Structural strength of weld connections

Internal and external notches as well as unfavourable wall thickness variations give rise to connection strengths which are possibly lower than the material strength. Weld connections always represent a non-homogeneity. As weld seams are in most cases not finished off, this results in irregularities on the surface which cause a reduction in structural strength.

In the above figure (right column) four different corner joints of varied design are shown. If these corner joints are exposed to a bending stress then it is seen that right angled corner connections are generally much less favourable than rounded corners with bonding positions outside the curve. Curves always allow an essentially unhindered distribution of forces and result in an up to 10 times greater structural strength than conventional right angled corner connections.

T shaped connections with one-sided weld seams show considerably less favourable behaviour than those welded on both sides (see figure below). It is important that there are no notches on the side of the part which will be stretched in use. The structural strength is favourably affected by rounding off the fillet seams and thereby having a positive effect on the distribution of forces.

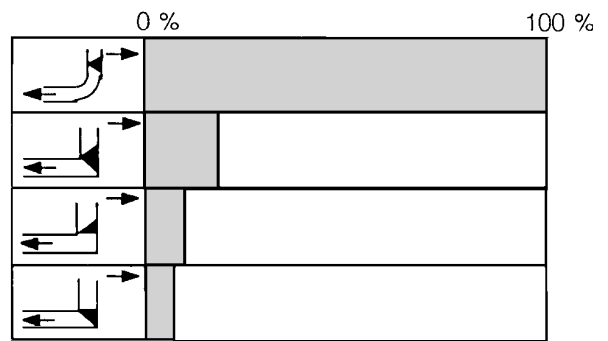

Angled welding connections

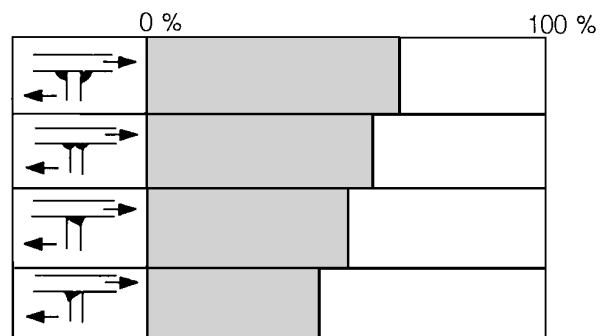

T shaped welding connections

Connections represented in the below figure are subject to a tensile stress. Tensile or shear stresses arise in the seam area. A finished V seam produces a high structural strength because the distribution of forces is not impeded and the notch effect is minimized. With single strapped connections shearing and tensile forces as well as bending moments arise in the welded seam. The structural strength is very low because the distribution of forces is greatly impeded. In contrast double strapped connections allow a favourable distribution of forces. This type of connection possesses a high structural strength. The same applies to cross connections.

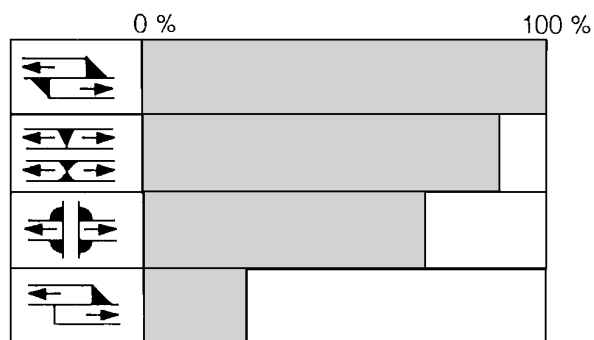

Plain welding connections

8.2 Weld seam position

The following examples of shapes are to be considered in connection with and in addition to DVS 2205 Sheet 3.

With load-bearing seams or fillet seams the weld seams should be so dimensioned that the required cross-sections are sufficient for the transmission of forces. Butt joints are to be preferred.

V seams should be counter welded at the root face.

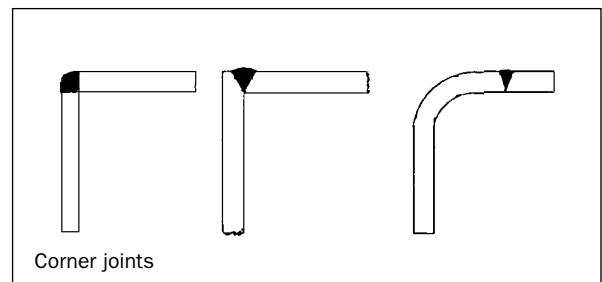

Corner joints

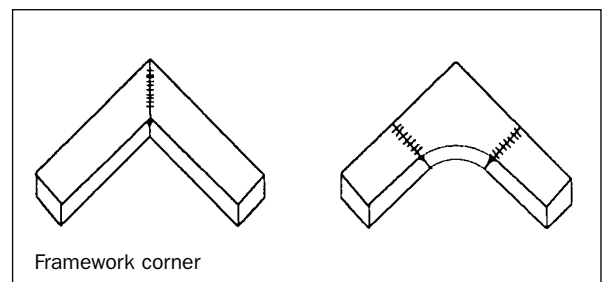

Framework corner

Examples for corner arrangements

At butt joints involving different wall thicknesses a cross over of the force distributions should be aimed for.

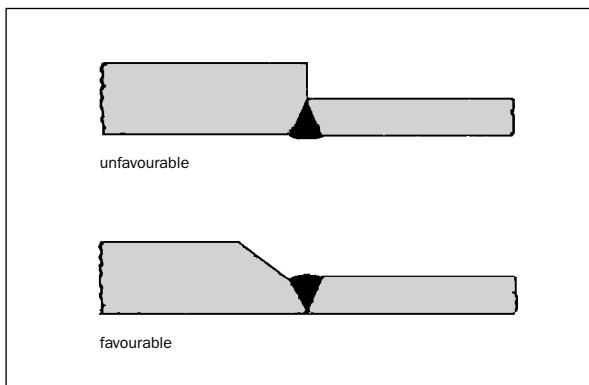

Examples for cross-section changes

Grouping together weld seams should be avoided. Intersecting seams are inadmissible.

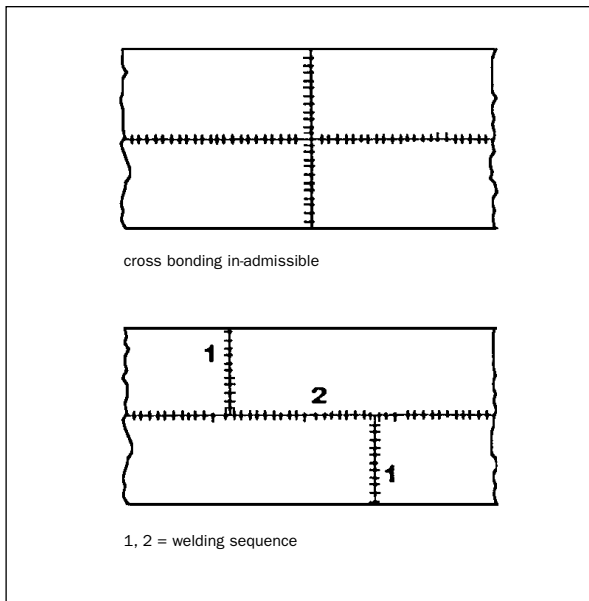

Examples for grouping together weld seams

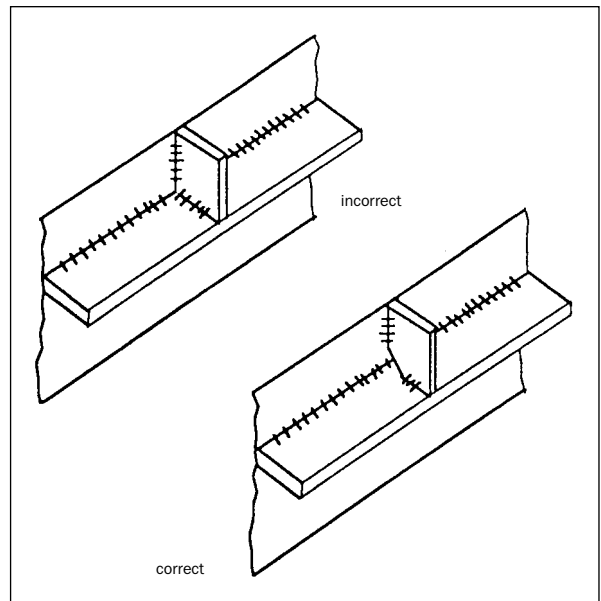

Reinforcement connections

8.3 Stresses

When thermoplastics are welded various stress conditions arise depending on the welding method. These can develop across, along and, in the case of thicker materials, vertically within the weld seam. These stresses are caused by local heating linked to uneven cooling.

On heating the material in the weld seam zone compression stresses are set up by thermal linear expansion. Relaxation of these stresses occurred during the welding process because of the plastic condition of stresses form. During the following cooling, thermal tension stresses develop. While the appearance of longitudinal weld stresses in the cross-section of the weld seam is independent of the welding process this is not the case for the appearance of transverse stresses. The decisive point is whether the sheet to be welded is fixed or if it is able to contract. With hot gas welding the successive parts of the welding process are responsible for

the build up to lateral stresses: because of the already mentioned stress relaxation, thermal tension stresses appear in the start area. As welding progresses these material zones must now take up the similarly developing tension stresses. It follows that in the last zone to be welded tension stresses are maintained, in the first zones however tension stresses build up.

Development of welding stresses along the length of the weld seam for heated element and hot gas welding (acc. to Menges)

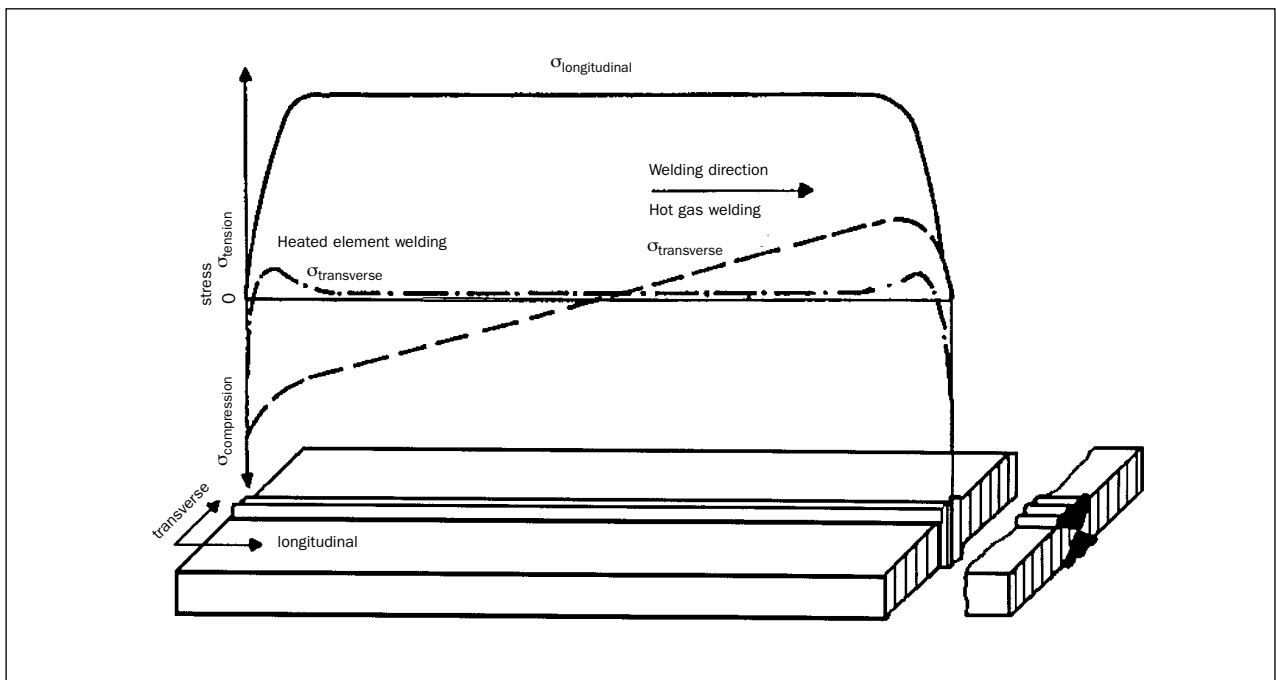

Development of the weld stresses over the direction at right angles to the weld seam. The level of the lateral stresses in the heated element butt seam is strongly dependent on the level and duration of the welding pressure (acc. to Menges)

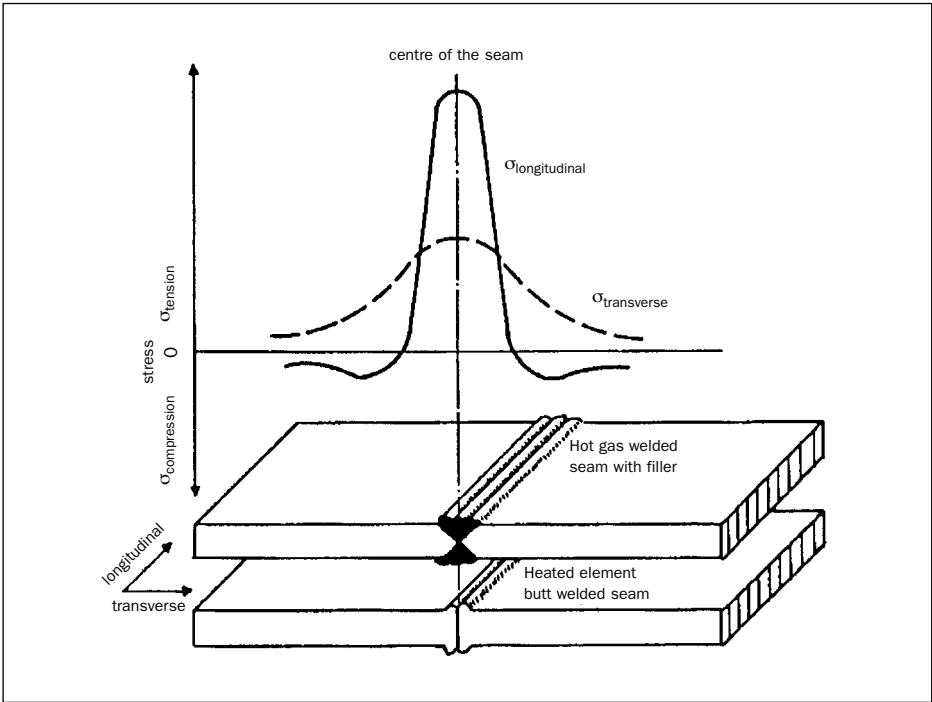

9 Advise

Our Sales and Applications Departments' personnel have many years experience in the processing and use of thermoplastic semi-finished materials.

We will be pleased to advise you.

10 Standards and sources

DVS instructions

2201	-2	(07.85)	Testing of semi-finished products of thermoplastics; weldability; test methods – requirements
2202	-1	(12.89)	Welding connection faults of thermoplastics; Characteristics, descriptions, valuation
2203			Testing of semi-finished products and welding joints of thermoplastics
	-1	(01.07)	test methods, requirements
	-2	(07.85)	tensile test
	-3	(07.85)	tensile impact test
	-4	(07.97)	tensile creep test
	-5	(08.99)	technological bending test
2204	-3	(04.81)	Adhesive bonding of thermoplastics
			Guidelines for adhesive bonding of unplasticized PVC and PVC-C will be worked out.
2205			Calculation of containers and apparatus made from thermoplastics
	-1	(04.02)	characteristic values
	-2	(10.00)	static, circular, non-pressurized containers
	-3	(04.75)	welded connections
	-4	(11.88)	flanged joints
	-5	(07.87)	rectangular tanks
	insert	(10.84)	Calculation of containers and apparatus made from thermoplastics, rectangular tanks, constructive details
2206		(11.75)	Testing of components and constructions made of thermoplastic material
2207			Welding of thermoplastics,
	-1	(09.05)	heated element butt welding of pipes, pipeline parts and sheets of PE-HD
	-3	(08.03)	hot gas welding of thermoplastics – sheets and pipes – welding parameter
	-4	(08.03)	extrusion welding; sheets and pipes
	-6		welding of thermoplastics; contactless heated element butt welding of pipes, pipeline parts and sheets; methods – machines – parameter
	-11	(02.99)	heated element butt welding of thermoplastics, pipes, pipeline parts and sheets of PP
	-15	(08.96)	heated element butt welding of pipes, pipeline parts and sheets of PVDF

2208 -1	(12.97)	Machines and equipment for welding of thermoplastic material; heated element welding
-2	(09.78)	Welding of thermoplastic materials; machines and equipment for hot-gas welding (not extrusion welding)
2209 -1	(12.81)	Welding of thermoplastic materials, extrusion welding, method; characteristics
-2	(08.97)	Hot-gas extrusion welding; requirements to welding machines and equipment
2210 -1	(04.97)	Industrial pipelines of thermoplastic materials; planning and execution, overground pipe systems
2211	(11.79)	Filler materials for thermoplastics; scope, designation, requirements, tests
2212 -1	(10.94)	Examination of welders, group 1

DVS instructions are issued by: Deutscher Verlag für Schweißtechnik GmbH, Aachener Str. 172, 40223 Düsseldorf

DIN standards

DIN ISO 857 -1	(11.02)	Welding and related processes; Metal welding processes
DIN EN 14610	(02.05)	Welding – terms; classification of welding processes
DIN 1910 -3	(1977)	Welding – Welding of thermoplastic materials; processes
DIN 16960 -1	(1974)	Welding of thermoplastic materials; general directions
DIN 16970	(1970)	Adhesive agents for bonding of pipes and pipelines of u-PVC; General quality requirements and tests

VDI guidelines

VDI 2003	Chipforming machining of thermoplastics
----------	---

DIN standards and VDI guidelines are issued by: Beuth-Verlag, Postfach 1145, Burggrafenstr. 4-10, 10772 Berlin 30.

KRV guidelines

Klebeanleitung PVC-Druckleitungen

KRV guidelines are issued by: Kunststoffrohrverband e.V., Gütegemeinschaft Kunststoffrohre e.V.,
Dyhoffstr. 2, 53113 Bonn

References

- standards and guidelines mentioned above
- Hoechst brochure: "Umformen, Bearbeiten, Fügen"
- Hadick: Schweißen von Kunststoffen
- Taschenbuch DVS-Merkblätter und -Richtlinien, Fügen von Kunststoffen, Volume 68/IV, 10. edition, 2003

11 Appendix

Dependent on machine and working conditions a variation of the guide values, especially the pre-heating time, indicated in the following tables can be necessary. For that samples have to be made and tested.

Hot gas welding

DVS 2207-3

Guide values – Hot gas welding

material	air [l/min]	temperature measured 5 mm in the welding nozzle [°C]	speed [cm/min]			
			Ø fan welding nozzle [mm]		Ø high-speed welding nozzle [mm]	
			3	4	3	4
PE						
-HWU, -HWST	50–60	320–340	10–15	ca. 10	≤ 50	≤ 40
-HWU-B	50–60	300–340	10–15	ca. 10	≤ 50	≤ 40
-HML 500	50–60	270–300	–	–	≤ 25	≤ 20
PP						
-DWU, -DWST	50–60	320–340	approx. 10	< 10	≤ 50	≤ 40
-DWU-B	50–60	300–320	approx. 10	< 10	≤ 50	≤ 40
PPs	50–60	300–320	approx. 10	< 10	≤ 50	≤ 40
PVC						
-MZ	45–55	350–370	15–20	approx. 15	≤ 50	≤ 40
-GLAS	45–55	350–370	15–20	approx. 15	≤ 60	≤ 50
-CAW	45–55	350–380	15–20	approx. 15	≤ 60	≤ 50
-C	45–55	370–390	15–20	approx. 15	≤ 60	≤ 50
COPLAST-AS	45–50	340–360	20–25	15–20	approx. 100	approx. 75
SIMOCEL-AS	45–50	340–360	20–25	15–20	approx. 100	approx. 75
PVDF*	50–60	365–385	10–15	ca. 10	≤ 40	≤ 30
E-CTFE*	50–60	350–380	–	–	≤ 25	≤ 20
SIMOLUX	40–50	300–320	approx. 15–20	approx. 15	≤ 50	≤ 40

* To avoid an oxidation of the welding surface it is recommended to use inert gas (e.g. nitrogen).

Heated element butt welding

DVS 2207-1

Guide values – Heated element butt welding of SIMONA® PE-HWU/HWST sheets

sheet thickness	temperature*	adaption	pre-heating	change-over time	bonding	
		p ≈ 0.15 N/mm ² bead height [mm]	p ≈ 0.01 N/mm ² time [s]		p ≈ 0.15 N/mm ² time to full pressure [s]	cooling time under bonding pressure min. value [min]
[mm]	[°C]			max. time** [s]		
3	220	0.5	30	< 3	3.0	6.0
4	220	0.5	40	< 3	4.0	6.0
5	215	1.0	50	< 3	5.0	7.0
6	215	1.0	60	< 3	5.5	8.5
8	215	1.5	80	< 3	6.5	11.0
10	215	1.5	100	< 3	7.0	12.5
12	210	2.0	120	< 3	8.0	16.0
15	210	2.0	150	< 3	8.5	19.5
20	205	2.0	200	< 3	10.5	25.0
25	205	2.5	250	< 3	11.5	31.0
30	200	2.5	300	< 3	13.5	36.5
35	200	3.0	350	< 3	15.5	42.5
40	200	3.5	400	< 3	17.0	48.5
50	200	3.5	500	< 3	25.0	60.0
60	200	4.0	600	< 3	30.0	70.0
70	200	4.0	700	< 3	35.0	80.0

* For PE 100 a constant heated element temperature of 220 °C is recommended for all thicknesses.

** Change-over time should be kept as short as possible or else the plastified surfaces will solidify.

Heated element butt welding

DVS 2207-11

Guide values – Heated element butt welding of SIMONA® PP-DWU/DWST, PPs sheets

sheet thickness	temperature	adaption*	pre-heating	change-over time	bonding	
		$p = 0.01 \text{ N/mm}^2$	$p \leq 0.1 \text{ N/mm}^2$		$p \approx 0.1 \text{ N/mm}^2 \pm 0.01$	
[mm]	[°C]	bead high [mm]	time [s]	max. time** [s]	time to full pressure [s]	cooling time under bonding pressure min. value [min]
3	220	0.5	105	< 3	5	6
4	220	0.5	130	< 3	5	6
5	215	0.5	145	< 3	5-6	6-12
6	215	0.5	160	< 3	5-6	6-12
8	215	1.0	190	< 3	6-8	12-20
10	215	1.0	215	< 3	6-8	12-20
12	210	1.0	245	< 3	8-11	20-30
15	210	1.0	280	< 3	8-11	20-30
20	205	1.5	340	< 3	11-14	30-40
25	205	1.5	390	< 3	11-14	30-40
30	200	1.5	430	< 3	14-19	40-55
35	200	2.0	470	< 3	14-19	40-55
40	200	2.0	505	< 3	19-25	55-70
50	200	2.5	560	< 3	25-32	55-70

* Bead height on the heat element at the end of the adaption time (adaption under 0.1 N/mm^2)

** Change-over time should be kept as short as possible or else the plastified surfaces will solidify.

Heated element butt welding

Guide values – Heated element butt welding of SIMONA® PVC-CAW sheets

sheet thickness	temperature	adaption	pre-heating	change-over time	bonding	
		p ≈ 0.6 N/mm ²	p ≈ 0.06 N/mm ²		p ≈ 0.6 N/mm ²	
[mm]	[°C]	bead height [mm]	time [s]	max. time*	time to full pressure = 1 x wall thickness [s]	cooling time under bonding pressure min. value [min]
3	225–230	> 0.5	45	< 2	3	3
4	225–230	> 0.5	60	< 2	4	4
5	225–230	> 0.5	75	< 2	5	5
6	225–230	> 0.5	90	< 2	6	6
8	220–225	> 1.0	120	< 2	8	8
10	220–225	> 1.0	150	< 2	10	10
12	220–225	> 1.0	180	< 2	12	12
15	220–225	> 1.5	225	< 2	15	15
20	220–225	> 1.5	300	< 2	20	20
25	220–225	> 2.0	375	< 2	20	25
30	220–225	> 2.0	450	< 2	20	30

* Change-over time should be kept as short as possible or else the plastified surfaces will solidify.

Heated element butt welding

DVS 2207-15

Guide values – Heated element butt welding of SIMONA® PVDF sheets

sheet thickness	temperature	adaption*	pre-heating	change-over time	bonding	
		p ≈ 0.1 N/mm ²	p ≤ 0.01 N/mm ²		p ≈ 0.1 N/mm ²	
[mm]	[°C]	bead height [mm]	time = 10 x wall thickness +40 s time [s]	max. time** [s]	time to full pressure = 0.4 x wall thickness + 2.5 s [s]	cooling time under bonding pressure = 1.2 x wall thickness + 2 min [min]
3	245	0.5	70	< 3	3.5	5.5
4	245	0.5	80	< 3	4.0	7.0
5	245	0.5	90	< 3	4.5	8.0
6	240	0.5	100	< 3	5.0	9.0
8	240	1.0	120	< 3	5.5	11.5
10	240	1.0	140	< 3	6.5	14.0
12	235	1.0	160	< 3	7.5	16.5
15	235	1.3	190	< 3	8.5	20.0
20	235	1.7	240	< 3	10.5	26.0
25	235	2.0	290	< 3	13.0	32.0
30	235	2.0	340	< 3	13.0	40.0
40	235	2.0	440	< 3	13.0	50.0
50	235	2.0	540	< 3	13.0	60.0

* Bead height on the heat element at the end of the adaption time (adaption under 0.1 N/mm²)

** Change-over time should be kept as short as possible or else the plastified surfaces will solidify.

For contactless heated element butt welding of PVDF a DVS guideline is valid:

Draft 2207-6 Welding of thermoplastic materials
 Contactless heated element butt welding of pipes, pipelines and sheets
 methods – machines – parameters

Heated element butt welding

Guide values – Heated element butt welding of SIMONA® E-CTFE sheets

sheet thickness	adaption	pre-heating	change-over	bonding	
	$p \approx 0.3 \text{ N/mm}^2$	$p \leq 0.05 \text{ N/mm}^2$	time	$p \approx 0.15 \text{ N/mm}^2$	
	bead height at the heat element before pre-heating			time to full pressure	cooling time under pressure= 100 x wall thickness
[mm]	bead height [mm]	time [s]	max. time* [s]	[s]	[min]
2.3	> 0.5	35	< 3	3	~ 5
3	> 0.5	45	< 3	4	~ 6
4	> 0.5	60	< 3	5	~ 8
5	> 0.5	75	< 3	6	~ 10

The heated element temperature is 260–270 °C.

* Change-over time should be kept as short as possible or else the plastified surfaces will solidify.

Attention! The heating elements of the well-known welding machines have a temperature limit of 250 °C. Therefore, please get in contact with the machine manufacturer.

Heated element butt welding

Guide values – Heated element butt welding of sheets of high molecular weight materials

material (bead height = 1 mm)	adaption pressure [N/mm ²]	pre-heating p = 0.01 N/mm ² [s]	change-over time time* [s]	time to full Pressure [s]	cooling	
					pressure [N/mm ²]	time [min]
PE-HML 500	10.00	sheet thickness in mm x 20 to 25	< 3	< 10	10.00	sheet thickness in mm x 1.5
PE-HMG 1000	30.00		< 3	< 10	30.00	

The heated element temperature is 200–210 °C.

* Change-over time should be kept as short as possible or else the plastified surfaces will solidify.

There are no guidelines for welding high-molecular weight materials.
However, the figures indicated above produce good results.

Heated element butt welding

DVS 2207-1

Guide values – Heated element butt welding of PE 80/PE 100 pipes

wall thickness [mm]	adaption $p \approx 0.15 \text{ N/mm}^2$ (1.5 kp/cm ²) bead height K before pre-heating [mm]	pre-heating $p \approx 0.01 \text{ N/mm}^2$ (0.1 kp/cm ²) time [s]	change-over time max. time* [s]	bonding $p \approx 0.15 \text{ N/mm}^2$ (1.5 kp/cm ²)	
				time to full pressure [s]	cooling time under pressure min. Value [min]
up to 4.5	0.5	45	5	5	6
4.5–7	1.0	45–70	5–6	5–6	6–10
7–12	1.5	70–120	6–8	6–8	10–16
12–19	2.0	120–190	8–10	8–11	16–24
19–26	2.5	190–260	10–12	11–14	24–32
26–37	3.0	260–370	12–16	14–19	32–45
37–50	3.5	370–500	16–20	19–25	45–60
50–70	4.0	500–700	20–25	25–35	60–80

The heated element temperature is 200–220 °C.

For PE 100 a constant heated element temperature of 220 °C is recommended for all thicknesses.

* Change-over time should be kept as short as possible or else the plastified surfaces will solidify.

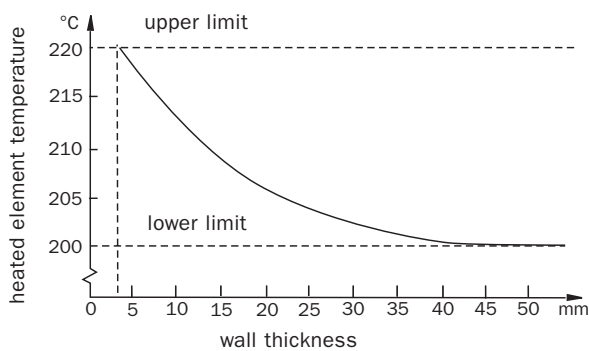

Guide values for heated element temperatures in relation to the wall thickness.

Heated element butt welding

DVS 2207-11

Guide values – Heated element butt welding of PP pipes

wall thickness	adaption bead height at the heat element before pre-heating (adaption under 0.1 N/mm ²)	pre-heating $p \leq 0.01 \text{ N/mm}^2$	change-over time	bonding	
				time to full pressure	cooling under bonding pressure
[mm]	[mm]	time [s]	max. time* [s]	[s]	min. value [min]
up to 4.5	0.5	135	5	6	6
4.5–7	0.5	135–175	5–6	6–7	6–12
7–12	1.0	175–245	6–7	7–11	12–20
12–19	1.0	245–330	7–9	11–17	20–30
19–26	1.5	330–400	9–11	17–22	30–40
26–37	2.0	400–485	11–14	22–32	40–55
37–50	2.5	485–560	14–17	32–43	55–70

The heated element temperature is $210 \pm 10 \text{ }^\circ\text{C}$.

* Change-over time should be kept as short as possible or else the plastified surfaces will solidify.

Heated element butt welding

DVS 2207-12, sheet 1

Guide values – heated element butt welding of pipes, fittings, sheets of PVC-U

wall thickness	temperature	adaption	pre-heating	change-over	bonding	
		0.6 N/mm ²	15 sec x s	time	time to full	cooling under
		bead height	p = 0.06 N/mm	max. time*	pressure	bonding pressure
[mm]	[°C]	[mm]	[s]	[s]	1 + s/2	0.6 N/mm ²
					[s]	2 min x s
						[min]
1.9	230	0.5	28,5	< 2	2	4
3	230	0.5	45	< 2	3	6
4	230	0.5	60	< 2	3	8
6	230	0.5	90	< 2	4	12
8	230	1.0	120	< 2	5	16
10	230	1.0	150	< 2	6	20
12	230	1.0	180	< 2	7	24
15	230	1.5	225	< 2	9	30
20	230	1.5	300	< 2	11	40
25	230	1.5	375	< 2	14	50

At an outdoor temperature of 20 °C ± 2 °C and light flow of air (no draught)

* Change-over time should be kept as short as possible or else the plastified surfaces will solidify.

Heated element butt welding

DVS 2207-15

Guide values – Heated element butt welding of PVDF pipes

wall thickness [mm]	adaption $p \approx 0.10 \text{ N/mm}^2$ (1.0 kp/cm ²) bead height K before pre-heating [mm]	pre-heating $p \leq 0.01 \text{ N/mm}^2$ (0.1 kp/cm ²) time = 10 x wall thickness + 40 s [s]	change-over time max. time* [s]	bonding	
				$p = 0.10 \text{ N/mm}^2$ (1.0 kp/cm ²) time to full pressure = 0.4 x wall thickness + 2.5 s [s]	cooling time under bonding pressure = 1.2 x wall thick- ness + 2 min min. value [min]
1.9–3.5	0.5	59–75	3	3–4	5–6
3.5–5.5	0.5	75–95	3	4–5	6–8.5
5.5–10.0	0.5–1.0	95–140	4	5–7	8.5–14
10.0–15.0	1.0–1.3	140–190	4	7–9	14–19
15.0–20.0	1.3–1.7	190–240	5	9–11	19–25
20.0–25.0	1.7–2.0	240–290	5	11–13	25–32

For PVDF a temperature of $240 \pm 8 \text{ }^\circ\text{C}$ is recommended.

* Change-over time should be kept as short as possible or else the plastified surfaces will solidify.

Heated element socket welding

DVS 2207-1 and 11

Guide values – Heated element socket welding of PE-80/100 and PP pipes

pipe diameter da [mm]	pre-heating time		change-over time max. admissible time [s]	cooling time (min. value)	
	SDR 11 [s]	SDR 17 [s]		clamped [s]	total [min]
16	5		4	6	2
20	5		4	6	2
25	7	1)	4	10	2
32	8	1)	6	10	4
40	12	1)	6	20	4
50	18	1)	6	20	4
63	24	1)	8	30	6
75	30	15	8	30	6
90	40	22	8	40	6
110	50	30	10	50	8
125	60	35	10	60	8

1) not recommended because of the reduced wall thickness
The heated element temperature is 260 ± 10 °C.

Heated element socket welding

DVS 2207-15

Guide values – Heated element socket welding of PVDF pipes

pipe diameter d [mm]	pre-heating time [s]	change-over time max. admissible time [s]	cooling ¹⁾ time (min. value)	
			clamped [s]	total [min]
16	4	4	6	2
20	6	4	6	2
25	8	4	6	2
32	10	4	12	4
40	12	4	12	4
50	18	4	12	4
63	20	6	18	6
75	22	6	18	6
90	25	6	18	6
110	30	6	24	8

¹⁾ Welding by hand the parts to be joined must be fixed according to the temperature in column “clamped”.
Only after cooling time (see column “total”) the weld joint can be charged by further processing

The heated element temperature is 260 ± 10 °C.

Hot-gas string bead welding and hot-gas welding with torch separate from filler rod (WZ and WF)

DVS 2207-3, Insert 1 (8/03)

Guide values – Hot-gas string bead welding and hot-gas welding with torch separate from filler rod of pipes and sheets

welding methods	letter symbol	hot-gas temperature ¹⁾	hot-gas flow ²⁾	welding speed ³⁾	welding load for rod diameter	
		[°C]	[l/min]	[mm/min]	3 mm	4 mm
hot-gas welding with torch separate from filler rod WF	PE-HD ⁴⁾	300–320	40–50	70–90	8–10	20–25
	PP-H, PP-B, PP-R	305–315	40–50	60–85	8–10	20–25
	PVC-U	330–350	40–50	110–170	8–10	20–25
	PVC-C	340–360	40–50	55–85	15–20	20–25
	PVDF	350–370	40–50	45–50	15–20	25–30
Hot-gas string bead welding WZ	PE-HD ⁴⁾	320–340	45–55	250–350	15–20	25–35
	PP-H, PP-B, PP-R	320–340	45–55	250–350	15–20	25–35
	PVC-U	350–370	45–55	250–350	15–20	25–35
	PVC-C	370–390	45–55	180–220	20–25	30–35
	PVDF	365–385	45–55	200–250	20–25	30–35
	E-CTFE	350–380	50...60 Hot-Gas/nitrogen	220–250	10–15	no data
	FEP	380–390	50–60	60–80	10–15	no data
	MFA	395–405	50–60	60–80	10–15	no data
	PFA	400–410	50–60	70	10–15	no data

¹⁾ 5 mm measured in the nozzle at the centre of the main nozzle aperture

²⁾ intake of cold air at ambient pressure

³⁾ dependent on welding filler diameter and welded joint geometry

⁴⁾ PE 63, PE 80, PE 100

SIMONA worldwide

SIMONA AG

Teichweg 16

D-55606 Kirn

Phone +49 (0) 67 52 14-0

Fax +49 (0) 67 52 14-211

mail@simona.de

www.simona.de

Plant I/II

Teichweg 16

D-55606 Kirn

Phone +49(0) 67 52 14-0

Fax +49(0) 67 52 14-211

Plant III

Gewerbestraße 1-2

D-77975 Ringsheim

Phone +49(0) 78 22 436-0

Fax +49(0) 78 22 436-124

SIMONA S.A. Paris

Z.I. 1, rue du Plant Loger

F-95335 Domont Cedex

Phone +33(0) 1 39 35 49 49

Fax +33(0) 1 39 91 05 58

domont@simona-fr.com

SIMONA S.A. Lyon

Z.I. du Chanay

2, rue Marius Berliet

F-69720 Saint-Bonnet-de-Mure

Phone +33(0) 4 78 40 70 71

Fax +33(0) 4 78 40 83 21

lyon@simona-fr.com

SIMONA S.A. Angers

Z.I. 20, Bld. de l'Industrie

F-49000 Ecouflant

Phone +33(0) 2 41 37 07 37

Fax +33(0) 2 41 60 80 12

angers@simona-fr.com

SIMONA UK LIMITED

Telford Drive

Brookmead Industrial Park

GB-Stafford ST16 3ST

Phone +44(0) 1785 22 24 44

Fax +44(0) 1785 22 20 80

mail@simona-uk.com

SIMONA AG SCHWEIZ

Industriezone

Bäumlimattstrasse

CH-4313 Möhlin

Phone +41(0) 61 8 55 90 70

Fax +41(0) 61 8 55 90 75

mail@simona-ch.com

SIMONA S.r.l. ITALIA

Via Padana

Superiore 19/B

I-20090 Vimodrone (MI)

Phone +39 02 25 08 51

Fax +39 02 25 08 520

mail@simona.it

SIMONA IBERICA

SEMIELABORADOS S.L.

Doctor Josep Castells, 26-30

Polígono Industrial Fonollar

E-08830 Sant Boi de Llobregat

Phone +34 93 635 41 03

Fax +34 93 630 88 90

mail@simona-es.com

SIMONA-PLASTICS CZ, s.r.o.

Zděbradská ul. 70

CZ-25101 Říčany-Jažlovice

Phone +420 323 63 78 3-7/-8/-9

Fax +420 323 63 78 48

mail@simona-plastics.cz

www.simona-plastics.cz

SIMONA POLSKA Sp. z o.o.

ul. H. Kamieńskiego 201-219

PL-51-126 Wrocław

Phone +48(0) 71 3 52 80 20

Fax +48(0) 71 3 52 81 40

mail@simona.pl

www.simona.pl

SIMONA FAR EAST

LIMITED

Room 501, 5/F

CCT Telecom Building

11 Wo Shing Street

Fo Tan

Hongkong

Phone +852 29 47 01 93

Fax +852 29 47 01 98

sales@simona.com.hk

SIMONA AMERICA Inc.

PO Box 158

755 Oakhill Road

Mountaintop, PA 18707

USA

Phone +1 570 474 5106

Fax +1 570 474 6523

mail@simona-america.com

www.simona-america.com